



# MONFORTS ATC

Advanced Technology Center

GERMAN   
Technology



BLUECOMPETENCE  
Alliance Member  
Partner of the Engineering Industry  
Sustainability Initiative

- Special Thanks to our Sponsors
- Besonderer Dank an unsere Sponsoren



- Your Powerful Partners
- Ihre starken Partner



## ➤ Services rendered at the new MONFORTS ATC

- Machine presentation to customers
- Trials with customer fabric
- Training of operators and service personnel

## ➤ Range of application

- I. Continuous dyeing of woven fabrics
- II. Finishing of knitted fabrics
- III. Finishing of woven fabrics (general)
- IV. Finishing of Technical Textiles

## ➤ Serviceangebote im neuen MONFORTS ATC

- Maschinen- und Anlagenpräsentation für Kunden und Interessenten
- Versuche mit Kundenware
- Schulung von Maschinenbedienern und Servicepersonal

## ➤ Anwendungsbereiche

- I. Kontinuefärben von Webware
- II. Ausrüsten von Maschenware
- III. Ausrüsten von Webware (allgemein)
- IV. Ausrüsten von Technischen Textilien

- Infrastructure
- Ausstattung



## ➤ The Monforts Advanced Technology Center

With an all-embracing range of machines, the Monforts Advanced Technology Center offers customers and potential customers the possibility of carrying out extensive fabric trials under real production conditions: For absolute reliability in the finishing result and tailored machine engineering.

## ➤ Das Monforts Advanced Technology Center

Mit einem umfassenden Maschinenprogramm bietet das Monforts Advanced Technology Center allen Kunden und Interessenten die Möglichkeit, umfangreiche Warenversuche unter realen Produktionsbedingungen durchzuführen: Für absolute Sicherheit beim Veredlungsergebnis und maßgeschneiderte Maschinenteknik.

- ① ➤ Thermex CDR  
➤ Thermex CDR
- ② ➤ Montex 6500  
➤ Montex 6500
- ③ ➤ Montex 8000  
➤ Montex 8000
- ④ ➤ Colour Kitchen  
➤ Farbküche
- ⑤ ➤ Meeting Area  
➤ Besprechungsbereich
- ⑥ ➤ Storage Area  
➤ Stofflager

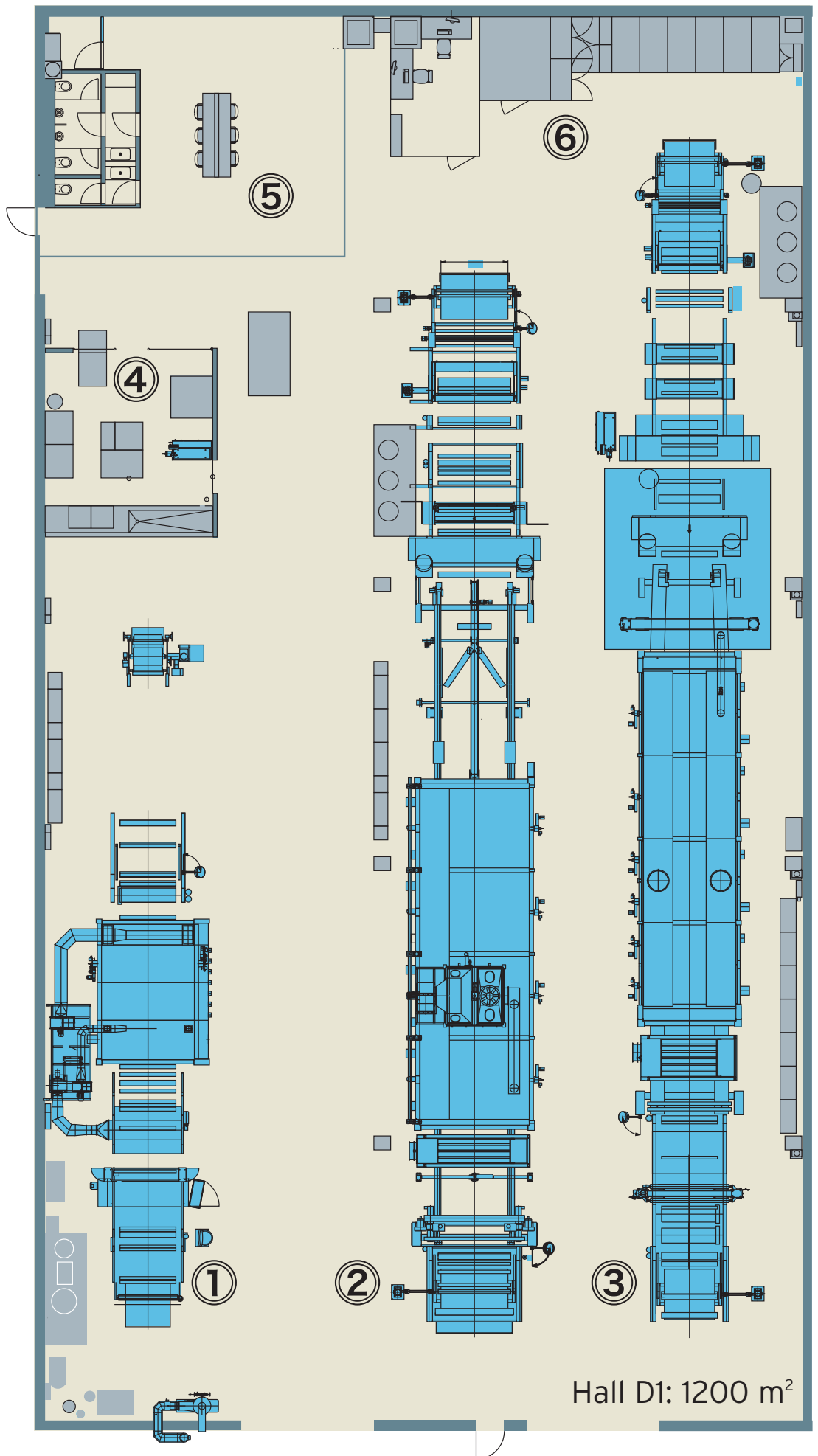

- Continuous dyeing, fabric width 60 - 180cm
- Kontinuierfärben, Warenbreite 60 - 180 cm



- Drying with  
Infrared predrier  
Hotflue
- Heat setting with  
Hotflue (Thermosol)  
Hotflue (Curing)
- ECO processes  
Econtrol®  
Econtrol® T-CA
- Effect processes  
Single-sided overdyeing of Denim  
Two-sided overdyeing of Denim
- Trocknen mit:  
Infrarot-Vortrockner  
Hotflue
- Fixieren mit:  
Hotflue (Thermosolieren)  
Hotflue (Kondensieren)
- Eco-Verfahren:  
Econtrol®  
Econtrol® T-CA
- Effekt-Verfahren:  
einseitiges Überfärben von Denim  
zweiseitiges Überfärben von Denim

- Econtrol® is a registered Trademark of DyStar Textilfarben GmbH & Co. Deutschland KG
- Econtrol® ist ein eingetragenes Warenzeichen von DyStar Textilfarben GmbH & Co. Deutschland KG

- Finishing of knitted fabrics, fabric width 60 - 240cm, Montex 4F, vertical chain
- Ausrüsten von Maschenware Warenbreite 60 - 240 cm, Montex 4F, vertikale Kette



- Liquor application with padder or Eco Applicator  
Finishing liquor  
Pigment dye liquor
- Weft straightening with weft straightener
- Selvage glueing
- Selvage cutting
- Steaming with V-steamer
- Drying with stenter
- Heat setting with stenter
- Curing with stenter

- Flottenauftrag über Foulard oder Eco Applicator mit:  
Ausrüstungsflotte  
Pigmentfarbflotte
- Schussrichten mit Schussrichter
- Kantenleimen
- Kantenschneiden
- Dämpfen mit V-Dämpfer
- Trocknen auf Spannrahmen
- Fixieren auf Spannrahmen
- Kondensieren auf Spannrahmen

- Finishing of woven fabrics  
fabric width 60 - 180cm, Montex 4F, combined chain
- Ausrüsten von Webware  
Warenbreite 60 - 180 cm, Montex 4F, Kombikette



- Liquor application with padder or Eco Applicator  
Finishing liquor  
Pigment dye liquor
- Weft straightening with weft straightener
- Drying with stenter
- Heat setting with stenter
- Curing with  
stenter  
Hotflue
- Flottenauftrag über Foulard oder Eco Applicator mit:  
Ausrüstungsflotte  
Pigmentfarbflotte
- Schussrichten mit Schussrichter
- Trocknen auf Spannrahmen
- Fixieren auf Spannrahmen
- Kondensieren auf  
Spannrahmen  
Hotflue



- Laboratory Equipment
- Laborausstattung



- |  |  |
|--|--|
| ➤ Colour Kitchen   | ➤ Farbküche  |
| ➤ Laboratory Eco-Applicator                              | ➤ Labor-Eco-Applicator                               |
| ➤ Equipment for washing tests                            | ➤ Geräte und Einrichtungen für Washtests             |
| ➤ Laboratory padder with different roller shore hardness | ➤ Labor-Foulard mit verschiedenen Walzen Shorehärten |
| ➤ Laboratory coating device                              | ➤ Labor-Beschichtungsanlagen                         |
| ➤ Laboratory dryer                                       | ➤ Labor-Trockner                                     |



- Finishing of Technical Textiles  
fabric width 60 - 180cm, Montex 4F, needle chain
- Ausrüsten von Technischen Textilien  
Warenbreite 60 - 180 cm, Montex 4F, Nadelkette



- Liquor application with padder or Eco Applicator  
Finishing liquor  
Pigment dye liquor
- Weft straightening with weft straightener
- Stretching (longitudinal) device up to 10.000 N/m
- Coating with  
Watery and solvent liquors  
Knife-over-air  
Knife-over-roll  
Commabar
- Stretching (widthwise) device up to 15.000 N/m
- Flottenauftrag über Foulard oder Eco Applicator mit:  
Ausrüstungsflotte  
Pigmentfarbflotte
- Schussrichten mit Schussrichter
- Reckwerk (in Längsrichtung),  
Reckkraft bis zu 10.000 N/m
- Beschichten mit:  
wässrigen und lösemittelhaltigen Flotten über:  
Luftrakel  
Walzenrakel  
Commabar
- Recken (in Querrichtung),  
Reckkraft bis zu 15.000 N/m

- Finishing of Technical Textiles  
fabric width 60 - 180cm, Montex 4F, needle chain
- Ausrüsten von Technischen Textilien  
Warenbreite 60 - 180 cm, Montex 4F, Nadelkette



- |  |   |
|--|---|
| <ul style="list-style-type: none"> <li>➤ Drying with stenter<br/>TwinTherm (temperature split upper/lower)<br/>Explosion protection (for finishing with solvents)</li> <li>➤ Heat setting with stenter Montex 4F<br/>(needle chain) up to max. 300°C</li> <li>➤ Vulcanizing with stenter up to max. 300°C</li> <li>➤ PVC-foaming with stenter up to max. 300°C</li> <li>➤ calendering</li> </ul> | <ul style="list-style-type: none"> <li>➤ Trocknen auf Spannrahmen<br/>TwinTherm (Temperatur-Split oben/unten)<br/>Explosionsschutz (für die Ausrüstung<br/>mit lösemittelhaltigen Chemikalien)</li> <li>➤ Fixieren auf Spannrahmen bis max. 300 °C</li> <li>➤ Vulkanisieren auf Spannrahmen bis max. 300 °C</li> <li>➤ PVC-Aufschäumen auf Spannrahmen bis max. 300 °C</li> <li>➤ Kalandrieren</li> </ul> |
|--|---|



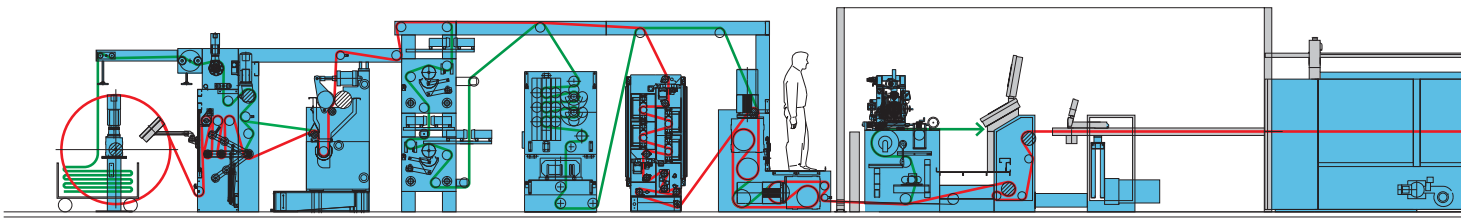

- Coating line for Technical Textiles
- Beschichtungsanlage für Technische Textilien

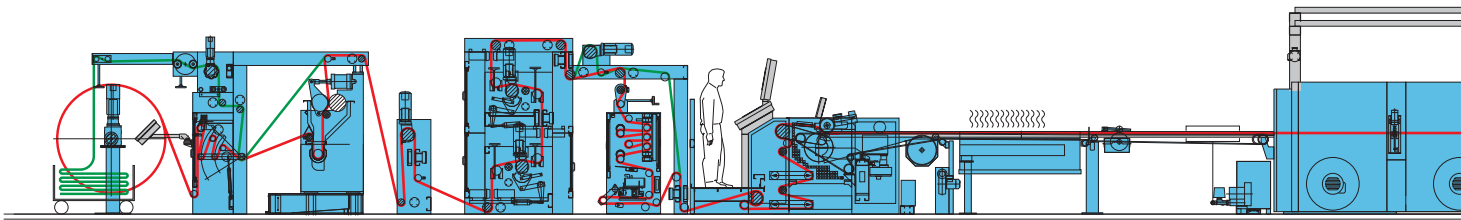

- Stenter for knitted fabrics
- Spannrahmen für Maschenware

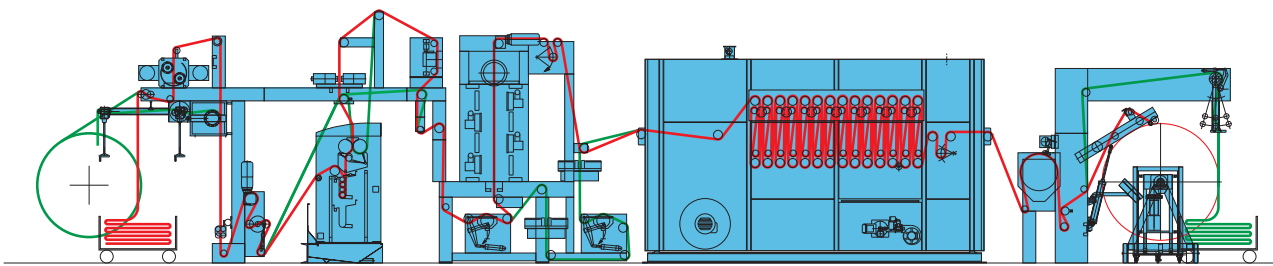

- Continuous dyeing range (Econtrol®) for woven fabrics
- Kontinuierfärbeanlage (Econtrol®) für Webware

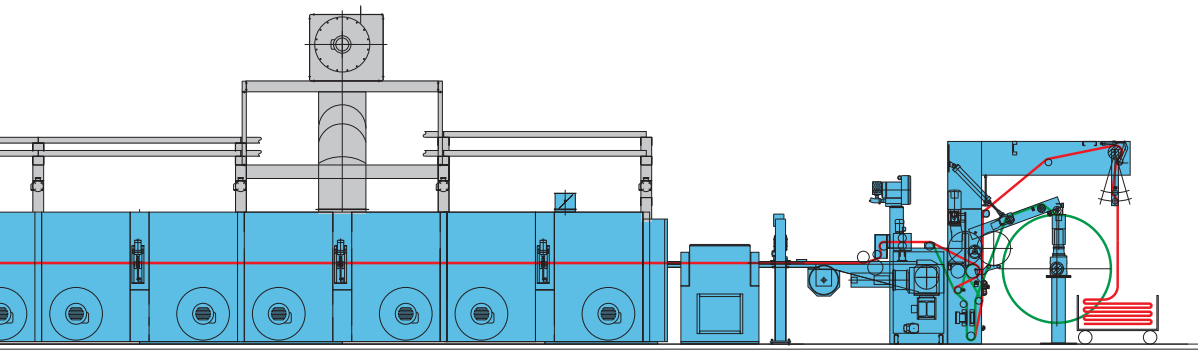
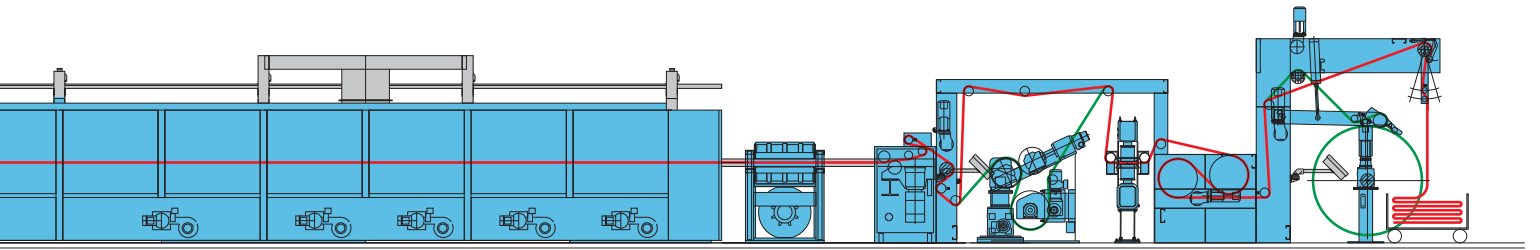

**BLUECOMPETENCE**  
Alliance Member

Partner of the Engineering Industry  
Sustainability Initiative



- Special applications
- Spezialverfahren

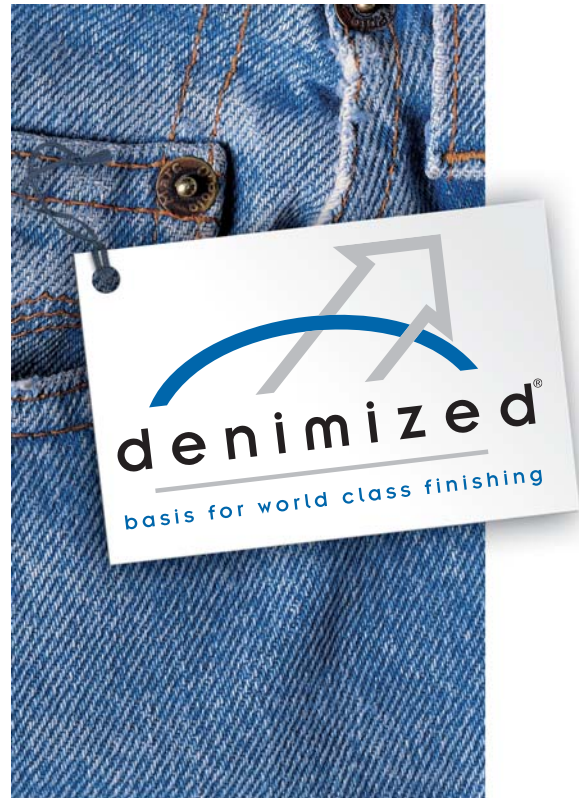

- Moist cross linking
  - Monforts MXL® (Hotflue)
  - Monforts MXL® (stenter)
- Denim
  - Partial mercerising (Hotflue)
  - Partial desizing (Hotflue)
  - Overdyeing
    - Single-sided
    - Two-sided
    - Two-sided with different dyes (Hotflue + stenter)

- Feuchtvernetzung
  - Monforts MXL® (Hotflue)
  - Monforts MXL® (Spannrahmen)
- Denim
  - Teilmerzerisieren (Hotflue)
  - Teilent-schichten (Hotflue)
  - Überfärben
    - einseitig
    - zweiseitig
    - zweiseitig mit unterschiedlichen Farben/Farbstoffen (Hotflue + Spannrahmen)

- Please contact us
- Nehmen Sie Kontakt mit uns auf



- Fabric trial with classical textiles:
- Versuche mit klassischen Textilien:
  - ✉ [technology@monforts.de](mailto:technology@monforts.de) ☎ + 49 2161 401 408
- Fabric trial with technical textiles:
- Versuche mit Technischen Textilien:
  - ✉ [techtex@monforts.de](mailto:techtex@monforts.de) ☎ + 49 2161 401 408



- Maintenance course:
- Bedienschulung:
  - ✉ [service@monforts.de](mailto:service@monforts.de) ☎ + 49 2161 401 420



- Operator training:
- Wartungskurs:
  - ✉ [service@monforts.de](mailto:service@monforts.de) ☎ + 49 2161 401 420





Monforts | Germany



Montex | Austria



Monforts ATC | Germany



Monfongs | China

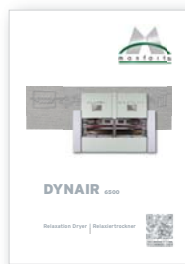

## A. Monforts Textilmaschinen GmbH & Co. KG

Germany | A Member of Fong's Industries Group

Postfach 10 17 01  
Blumenberger Straße 143 -145  
Telefon:  
Internet:  
eMail:

D-41017 Mönchengladbach  
D-41061 Mönchengladbach  
+ 49 - (0) - 21 61 - 401-0  
www.monforts.de  
info@monforts.de

GERMAN  Technology

